

PLAN W2

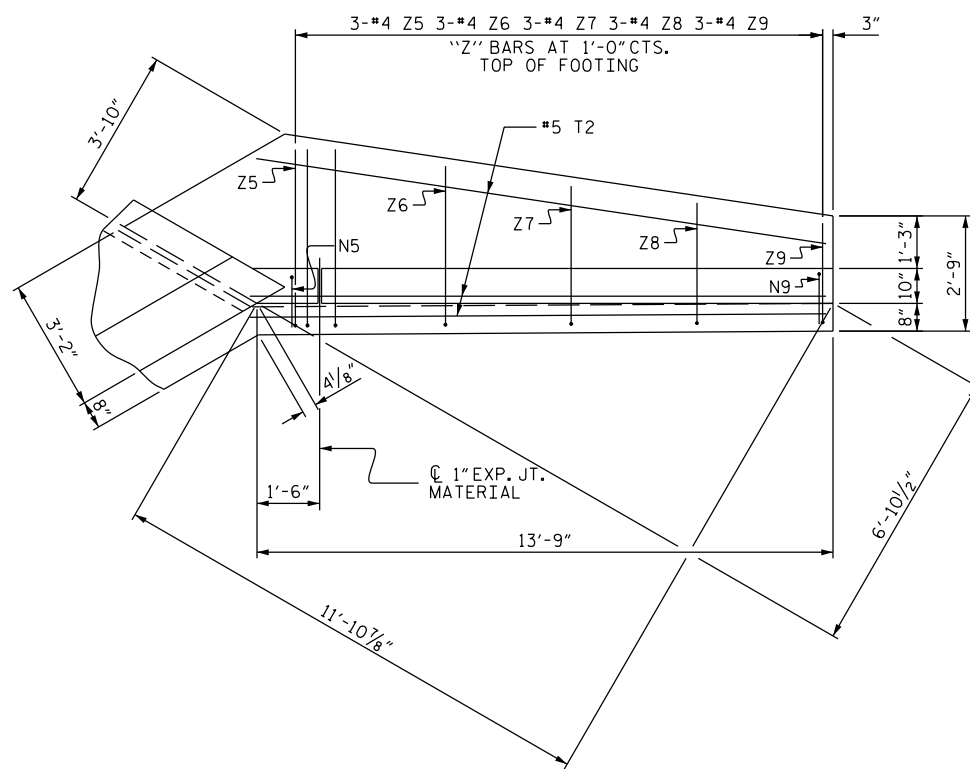

PLAN W1

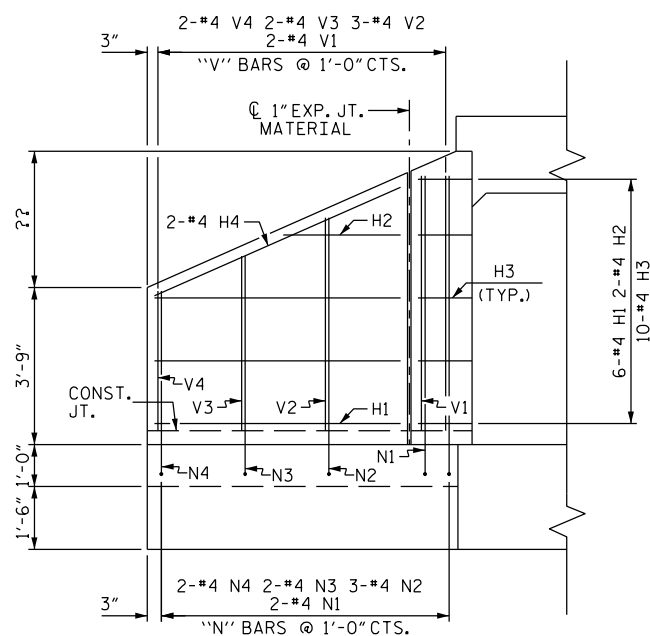

ELEVATION W2

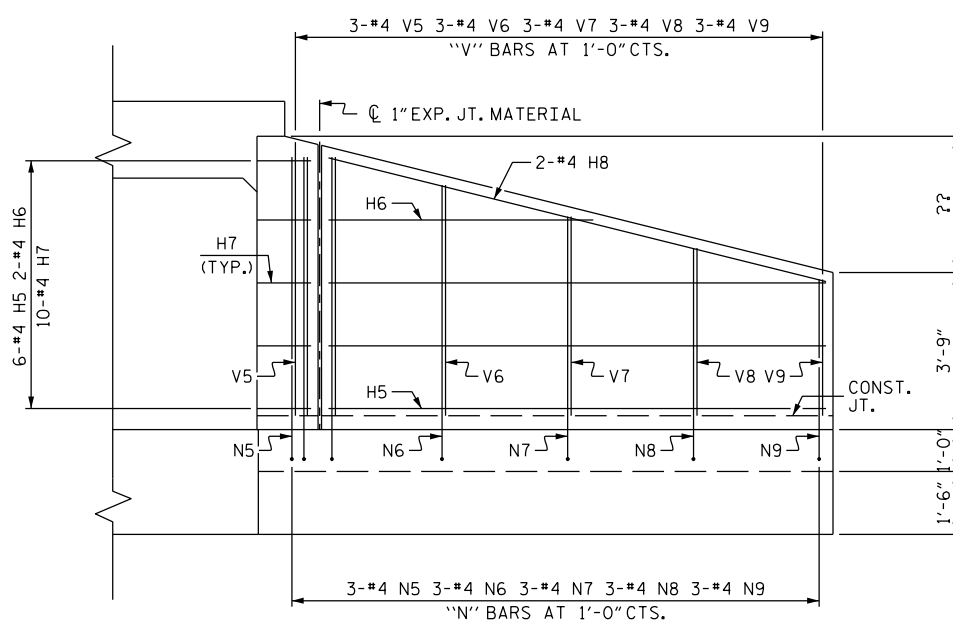

ELEVATION W1

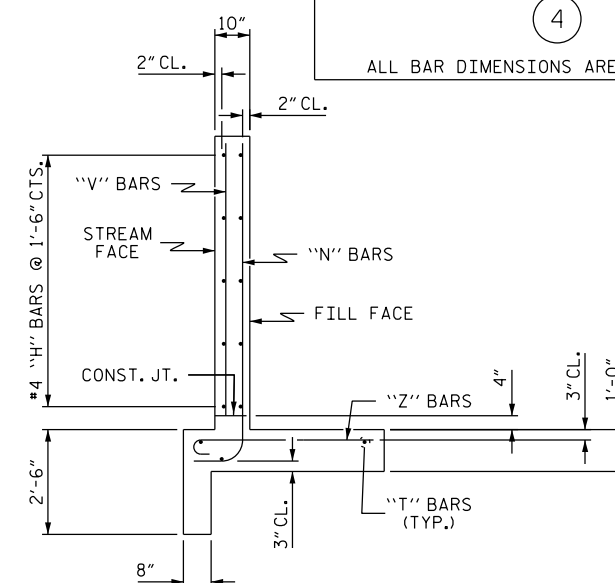

TYPICAL WING SECTION

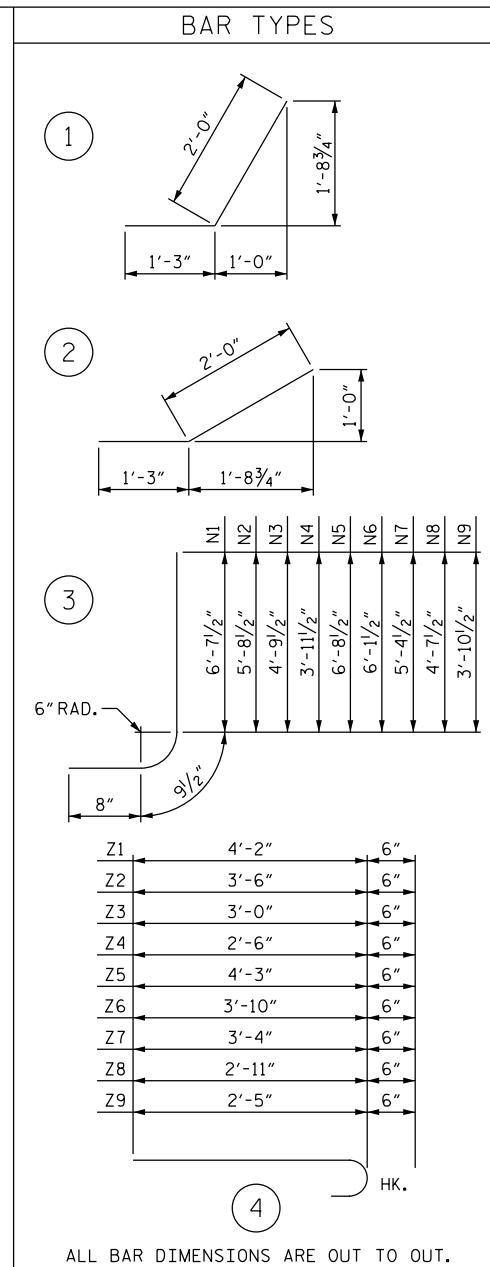

ALL BAR DIMENSIONS ARE OUT TO OUT.

BILL OF MATERIAL					
BAR	NO.	SIZE	TYPE	LENGTH	WEIGHT
H1	12	#4	STR	5'-10"	47
H2	4	#4	STR	2'-9"	7
H3	20	#4	1	3'-3"	43
H4	4	#4	STR	6'-5"	17
H5	12	#4	STR	11'-10"	95
H6	4	#4	STR	6'-3"	17
H7	20	#4	2	3'-3"	43
H8	4	#4	STR	12'-2"	33
N1	4	#4	3	8'-1"	22
N2	6	#4	3	7'-2"	29
N3	4	#4	3	6'-3"	17
N4	4	#4	3	5'-5"	14
N5	6	#4	3	8'-2"	33
N6	6	#4	3	7'-7"	30
N7	6	#4	3	6'-10"	27
N8	6	#4	3	6'-1"	24
N9	6	#4	3	5'-4"	21
T1	6	#5	STR	7'-9"	48
T2	6	#5	STR	13'-9"	86
V1	4	#4	STR	6'-1"	16
V2	6	#4	STR	5'-1"	20
V3	4	#4	STR	4'-2"	11
V4	4	#4	STR	3'-4"	9
V5	6	#4	STR	6'-2"	25
V6	6	#4	STR	5'-6"	22
V7	6	#4	STR	4'-9"	19
V8	6	#4	STR	4'-0"	16
V9	6	#4	STR	3'-3"	13
Z1	4	#4	4	4'-8"	12
Z2	6	#4	4	4'-0"	16
Z3	4	#4	4	3'-6"	9
Z4	4	#4	4	3'-0"	8
Z5	6	#4	4	4'-9"	19
Z6	6	#4	4	4'-4"	17
Z7	6	#4	4	3'-10"	15
Z8	6	#4	4	3'-5"	14
Z9	6	#4	4	2'-11"	12
REINFORCING STEEL FOR 4 WINGS				926	LBS
CLASS A CONCRETE					
4 WINGS				14.4	CY
2 HEADWALLS					CY
2 END CURTAIN WALLS					CY
TOTAL					CY

PROJECT NO. \_\_\_\_\_

\_\_\_\_\_ COUNTY

STATION: \_\_\_\_\_

SHEET \_\_\_\_\_ OF \_\_\_\_\_

STATE OF NORTH CAROLINA  
DEPARTMENT OF TRANSPORTATION  
RALEIGH  
STANDARD WINGS  
FOR  
CONCRETE BOX CULVERT  
H = 6'-0" SLOPE = 2:1  
60° SKEW

REVISIONS						SHEET NO.
NO.	BY:	DATE:	NO.	BY:	DATE:	TOTAL SHEETS
1			3			
2			4			

DOCUMENT NOT CONSIDERED FINAL UNLESS ALL SIGNATURES COMPLETED

ASSEMBLED BY : -	DATE : -
CHECKED BY : -	DATE : -
DRAWN BY : CCJ 11/99	REV. 6/19 MAA/THC
CHECKED BY : RWW 03/00	

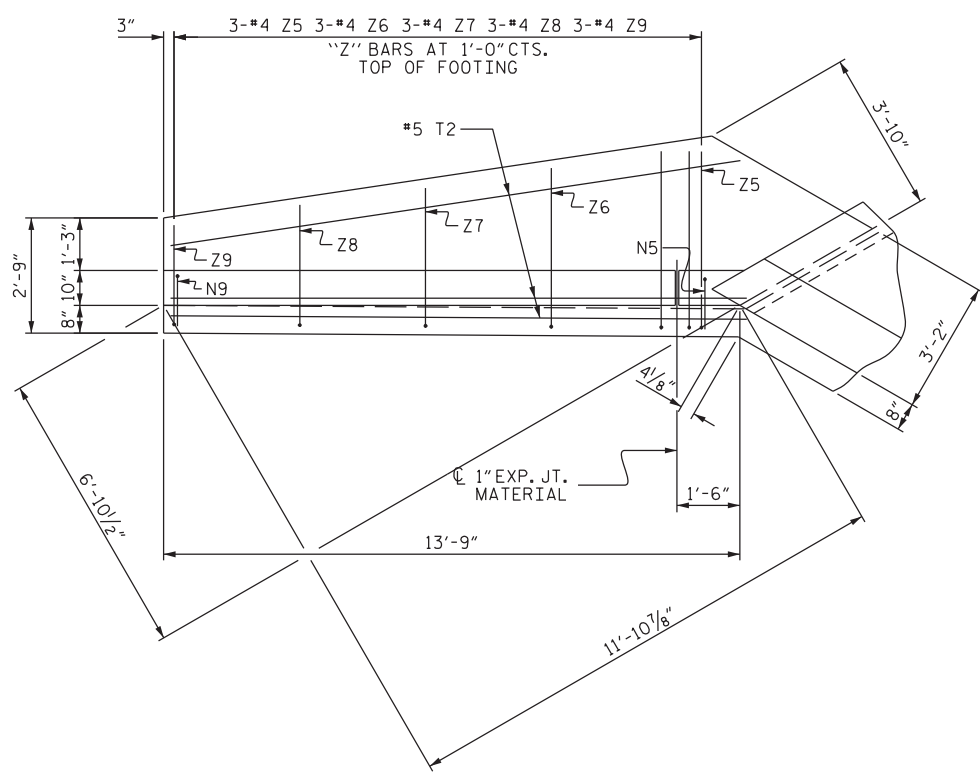

PLAN W1

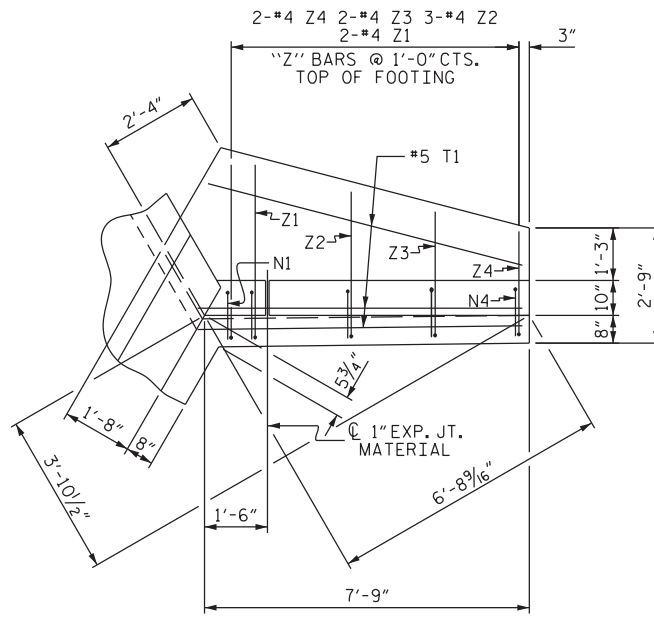

PLAN W2

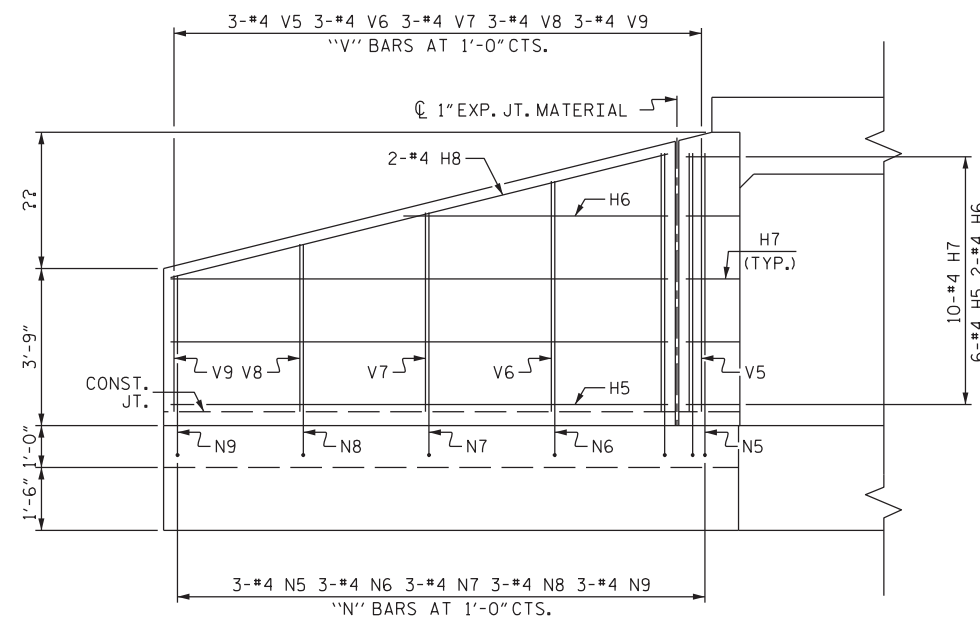

ELEVATION W1

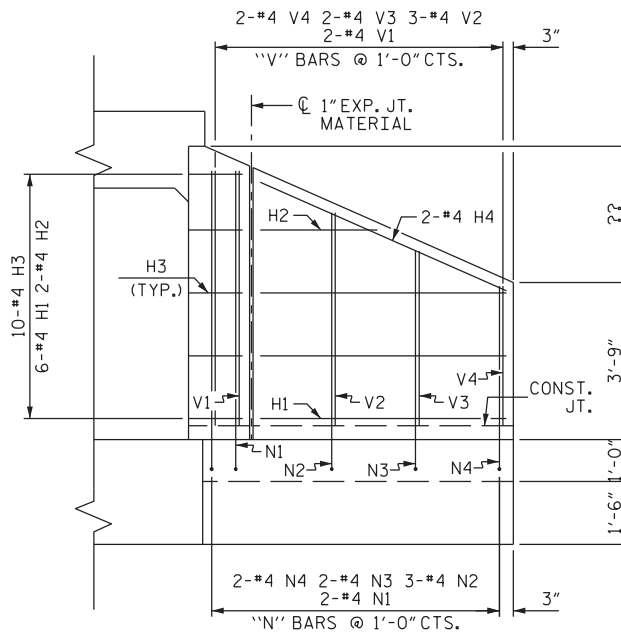

ELEVATION W2

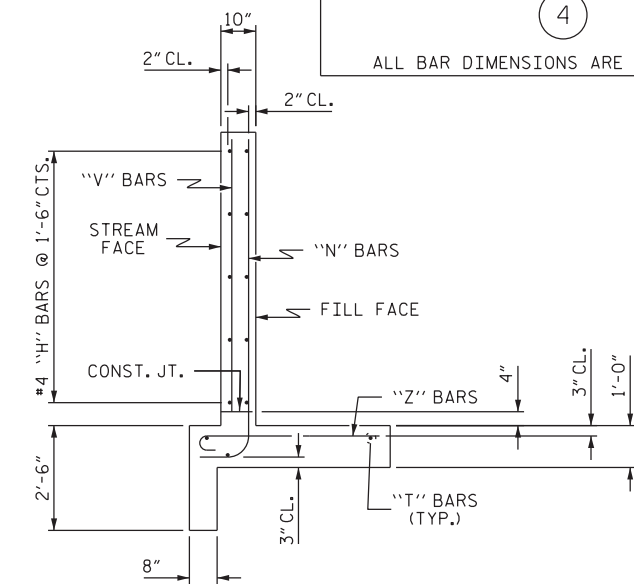

TYPICAL WING SECTION

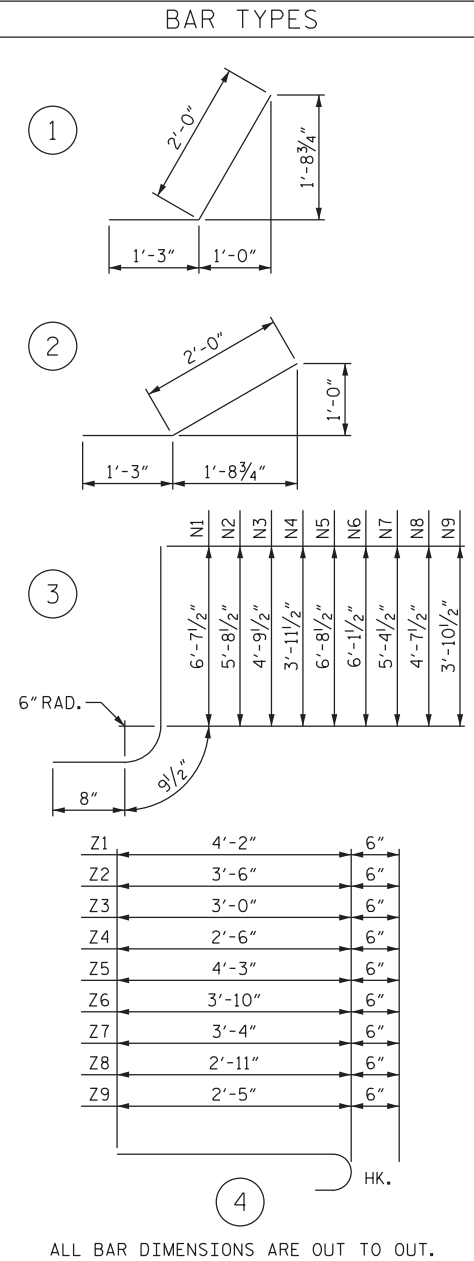

BILL OF MATERIAL					
BAR	NO.	SIZE	TYPE	LENGTH	WEIGHT
H1	12	#4	STR	5'-10"	47
H2	4	#4	STR	2'-9"	7
H3	20	#4	1	3'-3"	43
H4	4	#4	STR	6'-5"	17
H5	12	#4	STR	11'-10"	95
H6	4	#4	STR	6'-3"	17
H7	20	#4	2	3'-3"	43
H8	4	#4	STR	12'-2"	33
N1	4	#4	3	8'-1"	22
N2	6	#4	3	7'-2"	29
N3	4	#4	3	6'-3"	17
N4	4	#4	3	5'-5"	14
N5	6	#4	3	8'-2"	33
N6	6	#4	3	7'-7"	30
N7	6	#4	3	6'-10"	27
N8	6	#4	3	6'-1"	24
N9	6	#4	3	5'-4"	21
T1	6	#5	STR	7'-9"	48
T2	6	#5	STR	13'-9"	86
V1	4	#4	STR	6'-1"	16
V2	6	#4	STR	5'-1"	20
V3	4	#4	STR	4'-2"	11
V4	4	#4	STR	3'-4"	9
V5	6	#4	STR	6'-2"	25
V6	6	#4	STR	5'-6"	22
V7	6	#4	STR	4'-9"	19
V8	6	#4	STR	4'-0"	16
V9	6	#4	STR	3'-3"	13
Z1	4	#4	4	4'-8"	12
Z2	6	#4	4	4'-0"	16
Z3	4	#4	4	3'-6"	9
Z4	4	#4	4	3'-0"	8
Z5	6	#4	4	4'-9"	19
Z6	6	#4	4	4'-4"	17
Z7	6	#4	4	3'-10"	15
Z8	6	#4	4	3'-5"	14
Z9	6	#4	4	2'-11"	12
REINFORCING STEEL FOR 4 WINGS					926 LBS
CLASS A CONCRETE					
4 WINGS					14.4 CY
2 HEADWALLS					CY
2 END CURTAIN WALLS					CY
TOTAL					CY

ALL BAR DIMENSIONS ARE OUT TO OUT.

PROJECT NO. \_\_\_\_\_

\_\_\_\_\_ COUNTY

STATION: \_\_\_\_\_

SHEET \_ OF \_

STATE OF NORTH CAROLINA  
DEPARTMENT OF TRANSPORTATION  
RALEIGH

STANDARD WINGS  
FOR  
CONCRETE BOX CULVERT  
H = 6'-0" SLOPE = 2:1  
120° SKEW

ASSEMBLED BY : -	DATE : -
CHECKED BY : -	DATE : -
DRAWN BY : CCJ 11/99	REV. 6/19 MAA/THC
CHECKED BY : RWW 03/00	

REVISIONS						SHEET NO.
NO.	BY:	DATE:	NO.	BY:	DATE:	TOTAL SHEETS
1			3			
2			4			

DOCUMENT NOT CONSIDERED FINAL UNLESS ALL SIGNATURES COMPLETED